

PS-T01-30

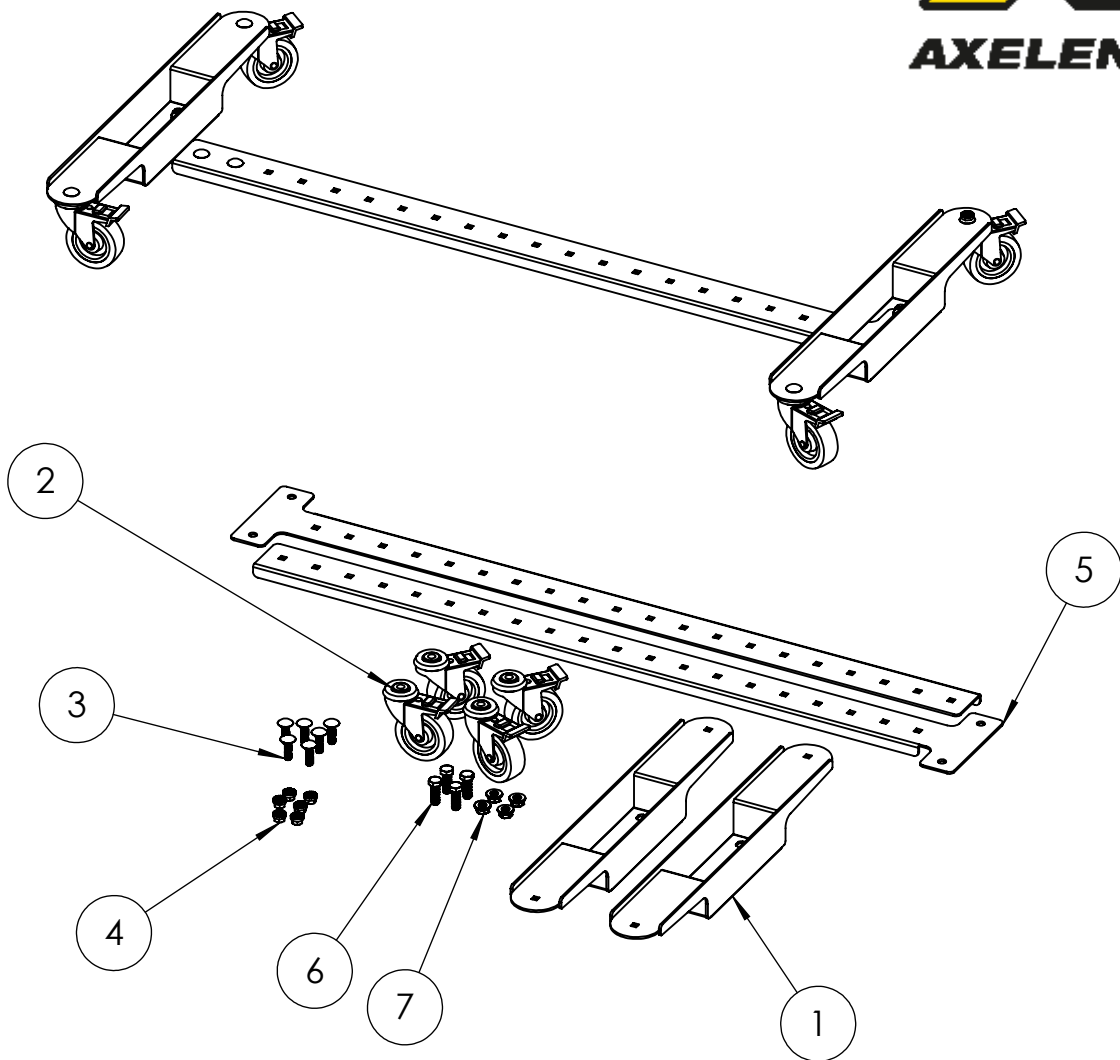

Date: 2018-06-18

Axelent AB

**BOX 1 · KÄVSJÖVÄGEN 17
SE-335 04 · HILLERSTORP
SWEDEN**

**TEL +46 (0)370-37 37 30
INFO@AXELENT.SE
AXELENT.COM**

ITEM NO.	Art.nr	QTY.
1	G2255	2
2	S-0120-08	4
3	MV/BF-M8.30	6
4	M6MF-M8	6
5	G2254	2
6	S-0136-32	4
7	10-9883	4

C-number (for internal use)	Drawing-ID	Part/Assembly/Config ID (for internal use)	Description / Article number	Version
C-0005065-01	PS-T01-30	Default(A-0003117)	Undercarriage kit for mobile panel (post 50x50)	A.0