

X-Guard

Equipotential bonding kit

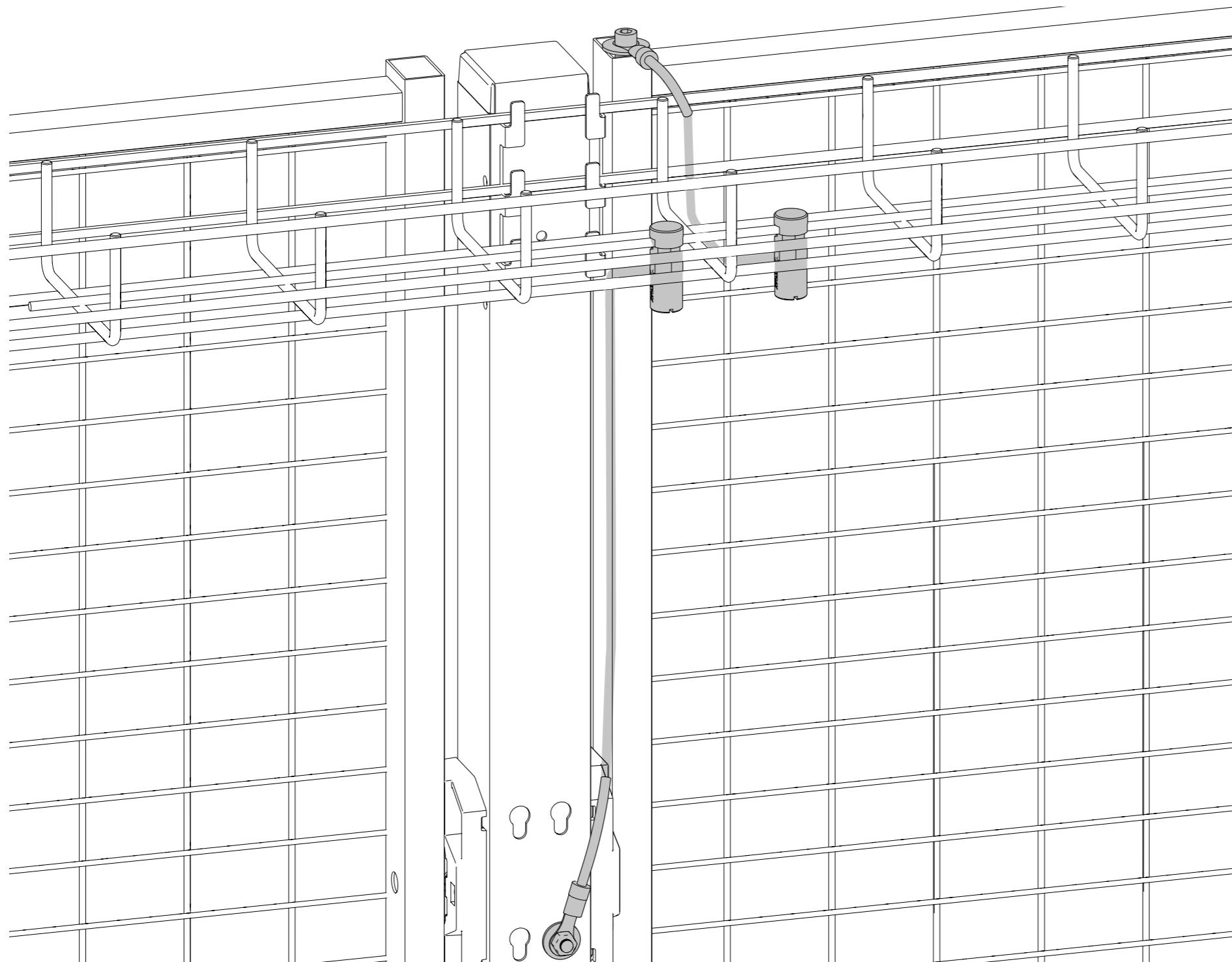

T01-43-6, T01-43-16, T01-44-6, T01-43-16

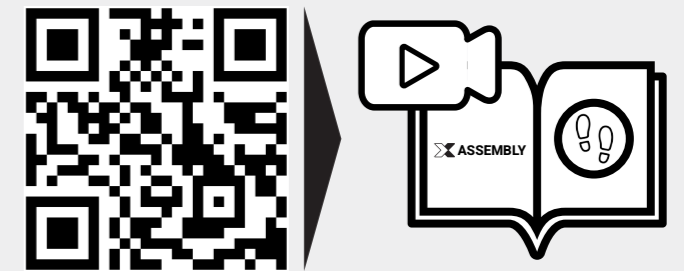

AXELENT AB • BOX 1
KÄVSJÖVÄGEN 17 • SE-335 73
HILLERSTORP • SWEDEN

TEL +46 (0)370-37 37 30
INFO@AXELENT.SE
WWW.AXELENT.COM



T01-43-6 / T01-43-16
page: 4

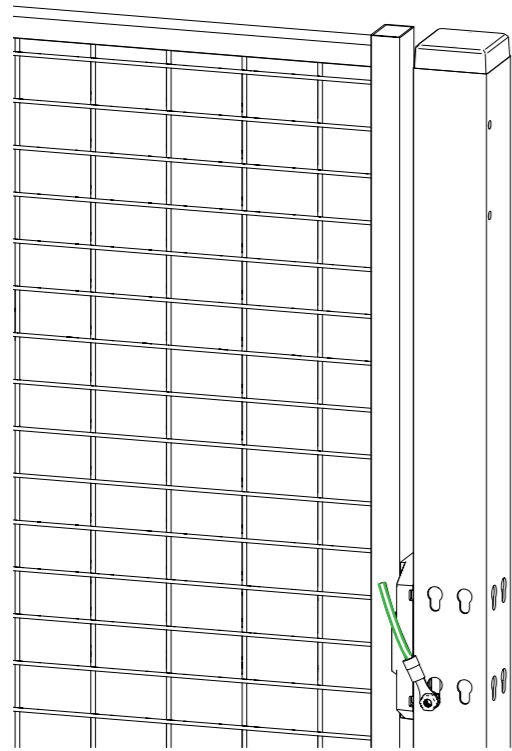

For optional placement on post, Page: 4
50x50

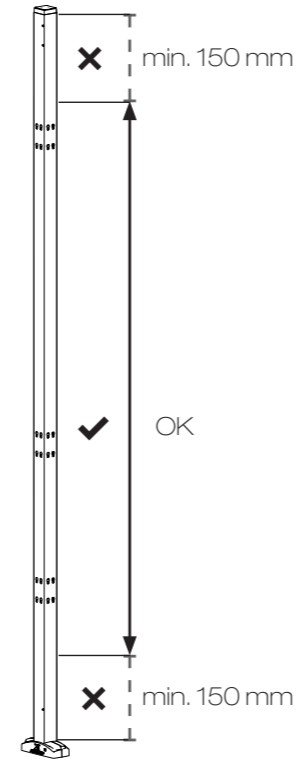
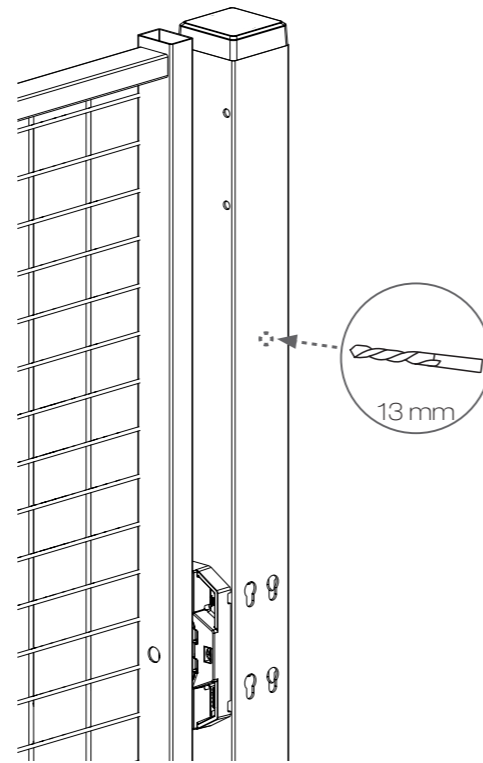

70x70

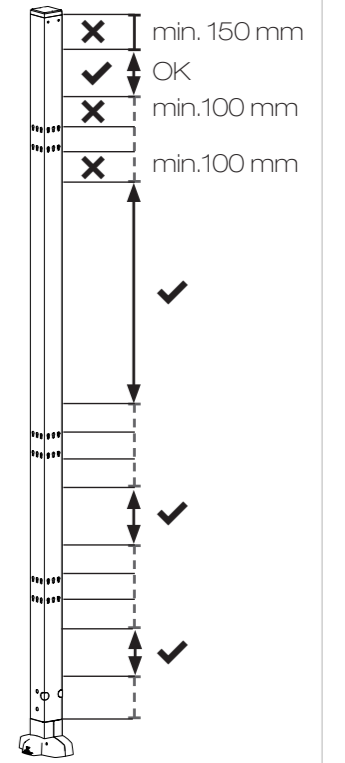
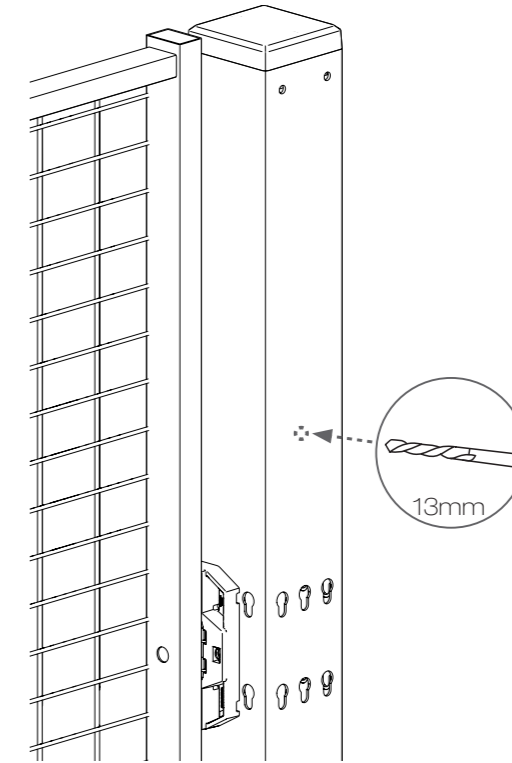

T01-44-6 / T01-44-16
page: 5

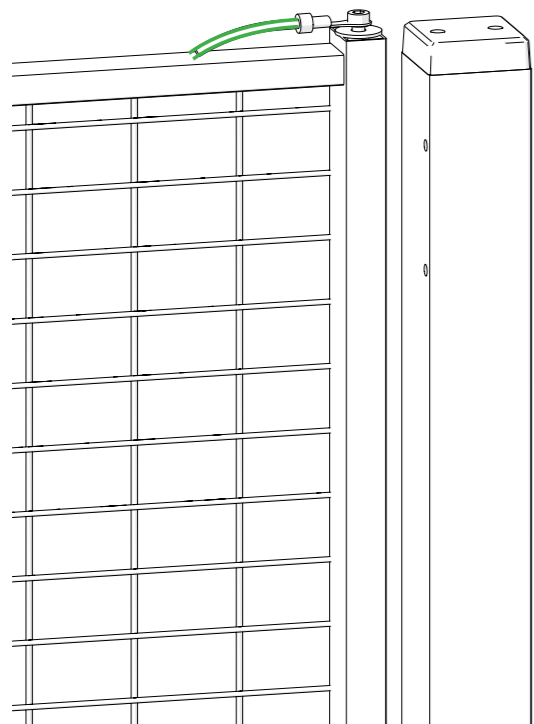

X-Tray products:

X-Tray: 0701-2300,
0711-2300, 0721-2300,
0731-2300, 0741-2300.

Top Bracket: 7700-015

X5 Joining Fitting: 2705

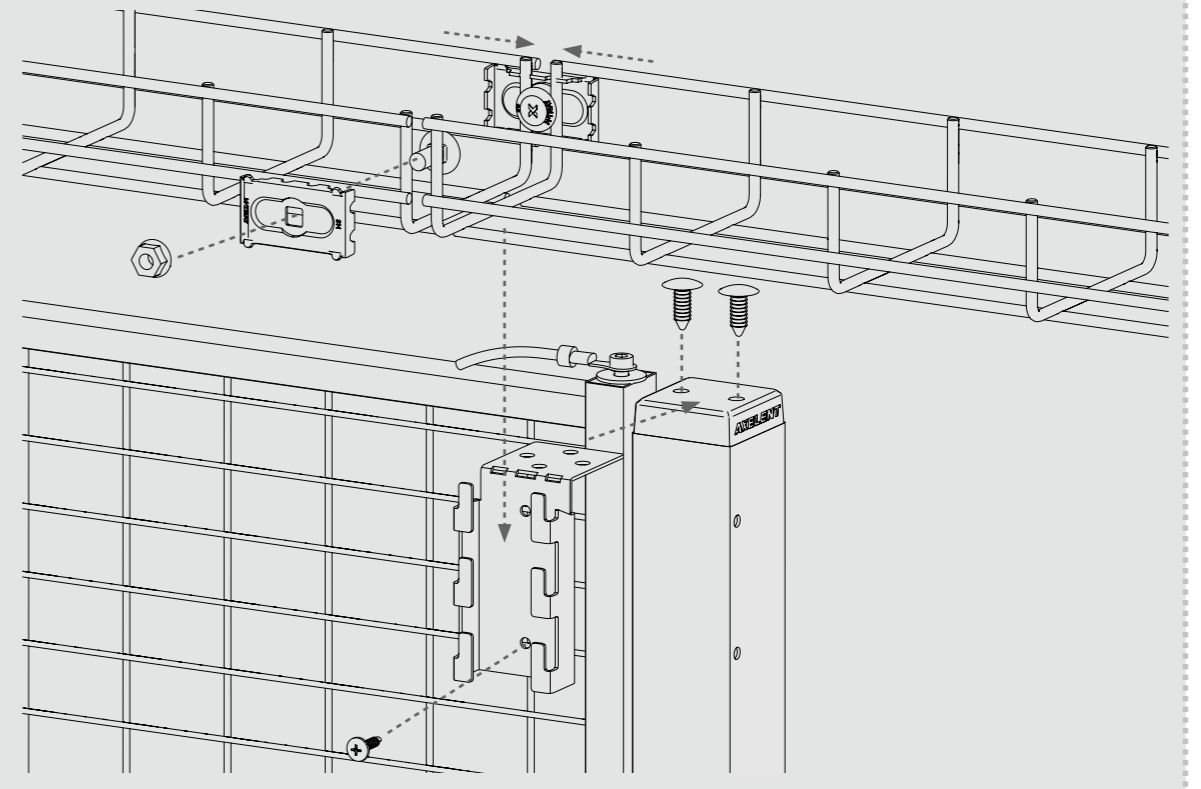

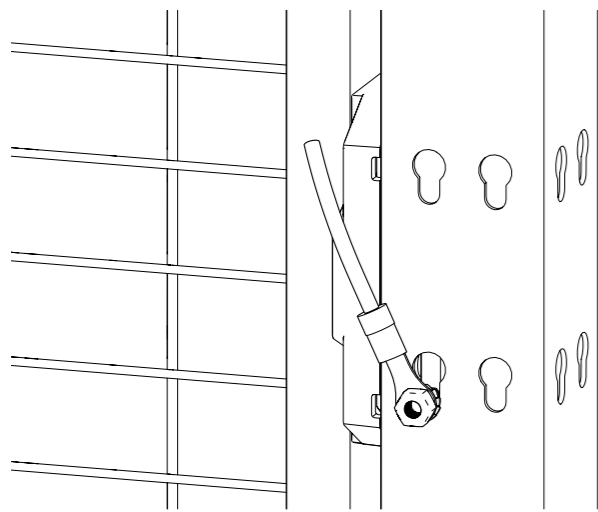

T01-43-6
T01-43-16

A

X 10

2568-1

X 10

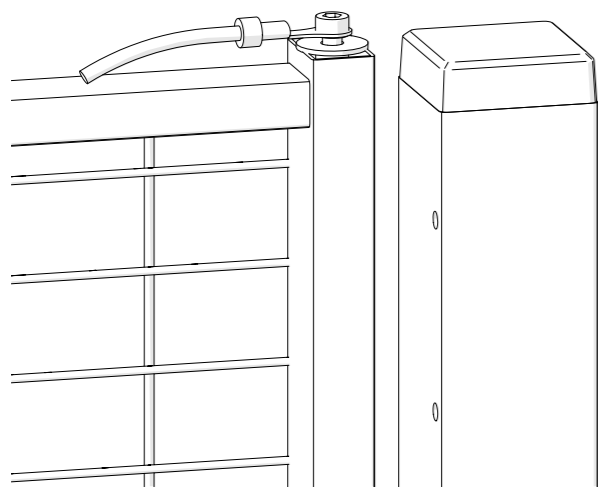

T01-44-6
T01-44-16

B

X 10

2568-1

X 10



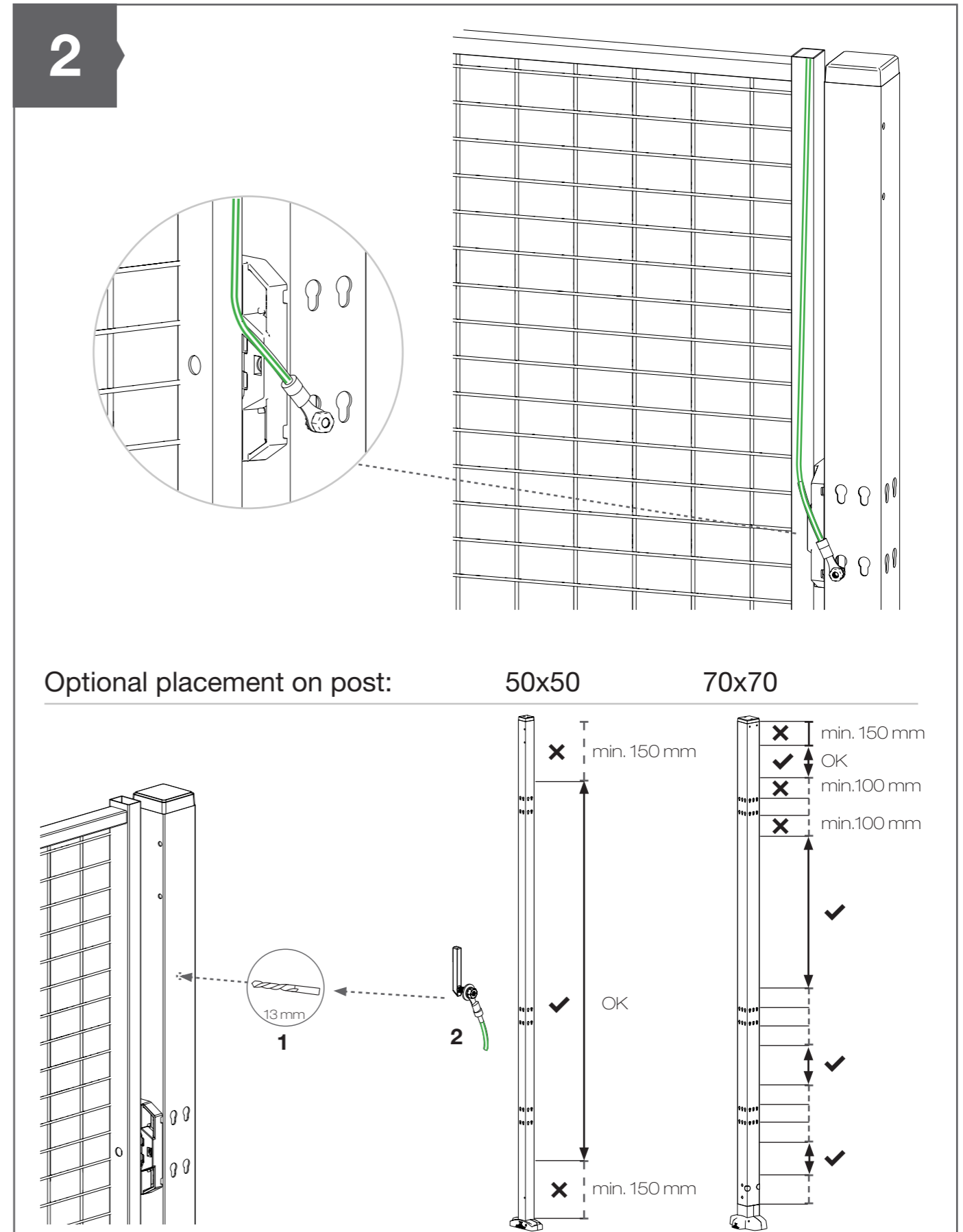
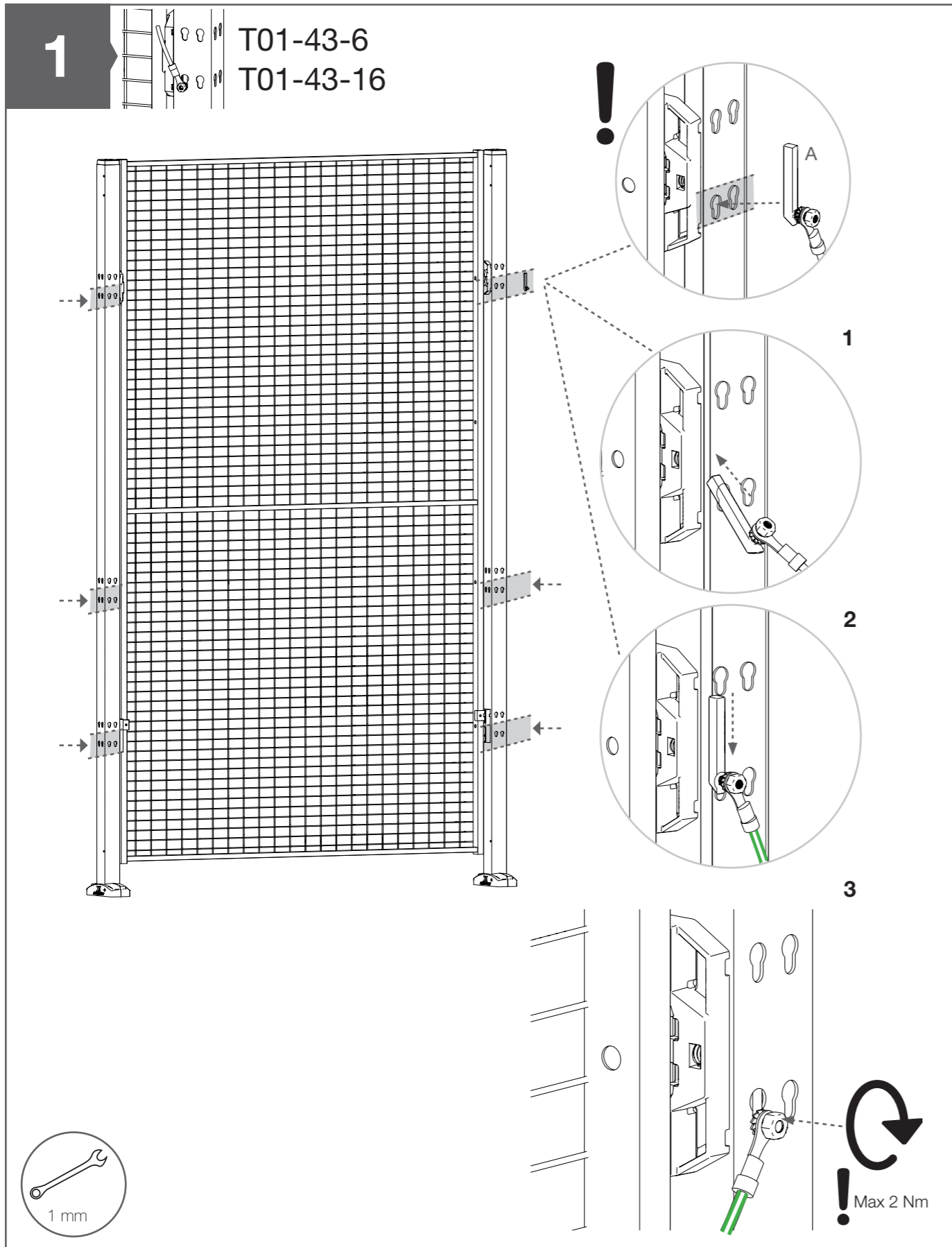

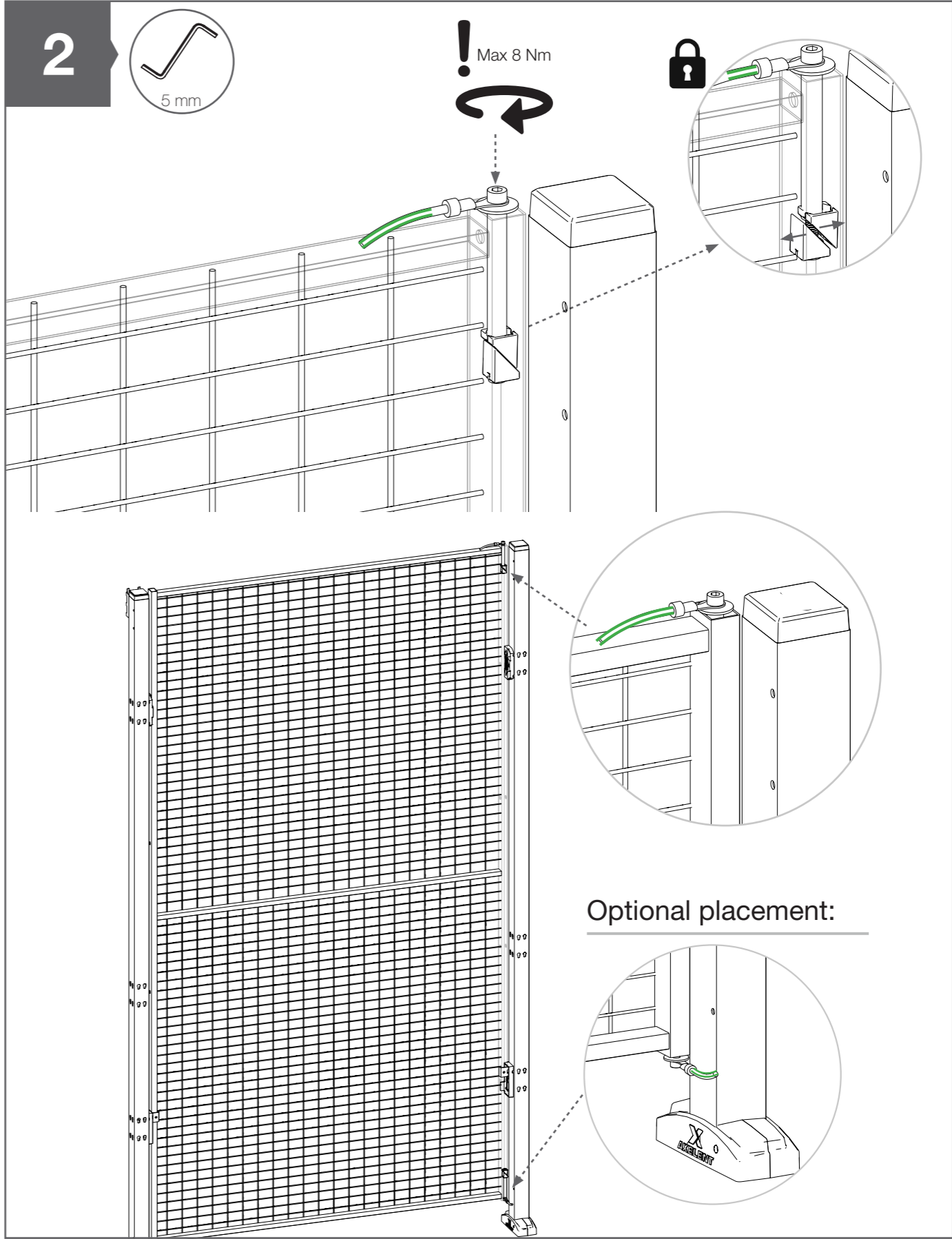
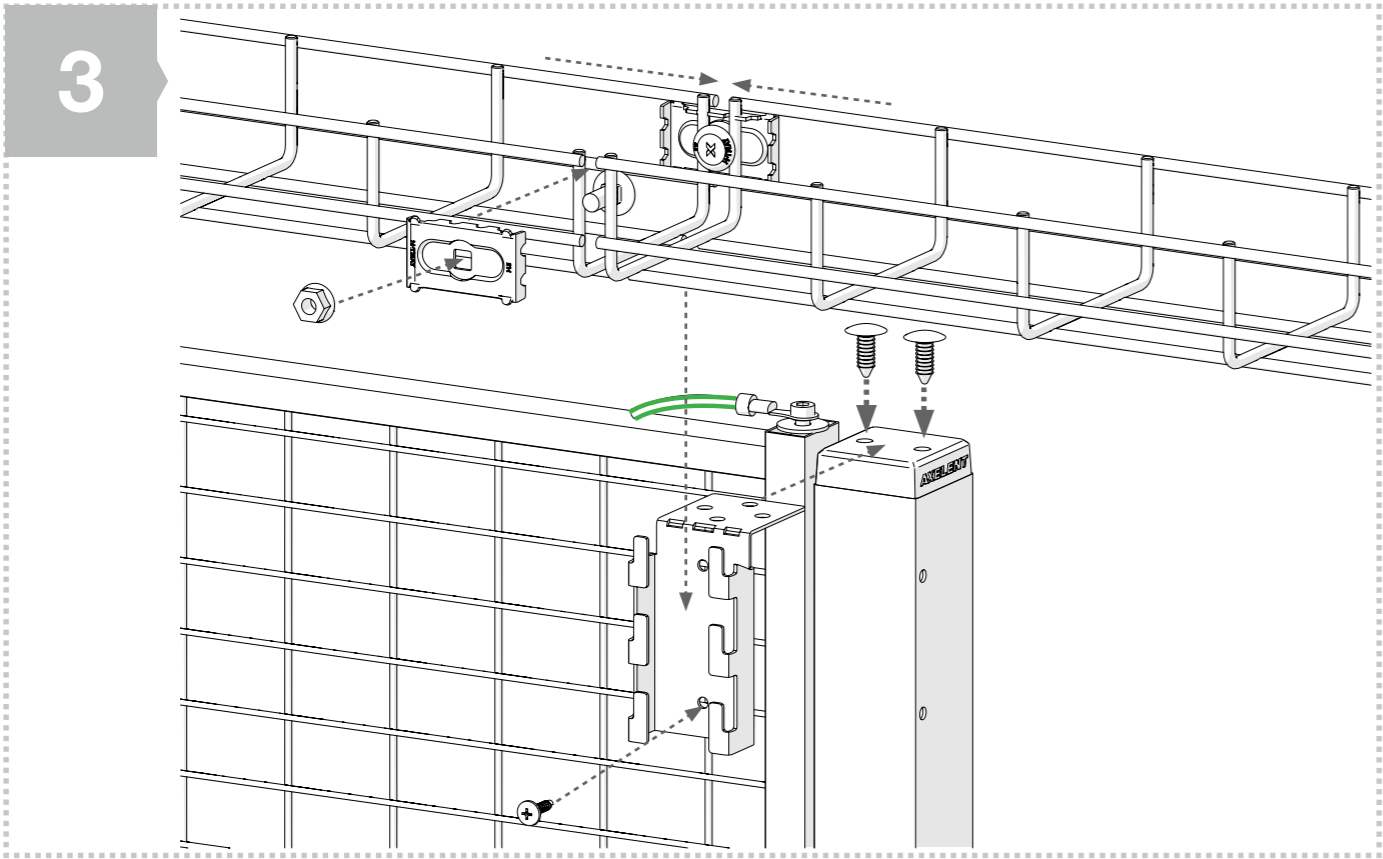
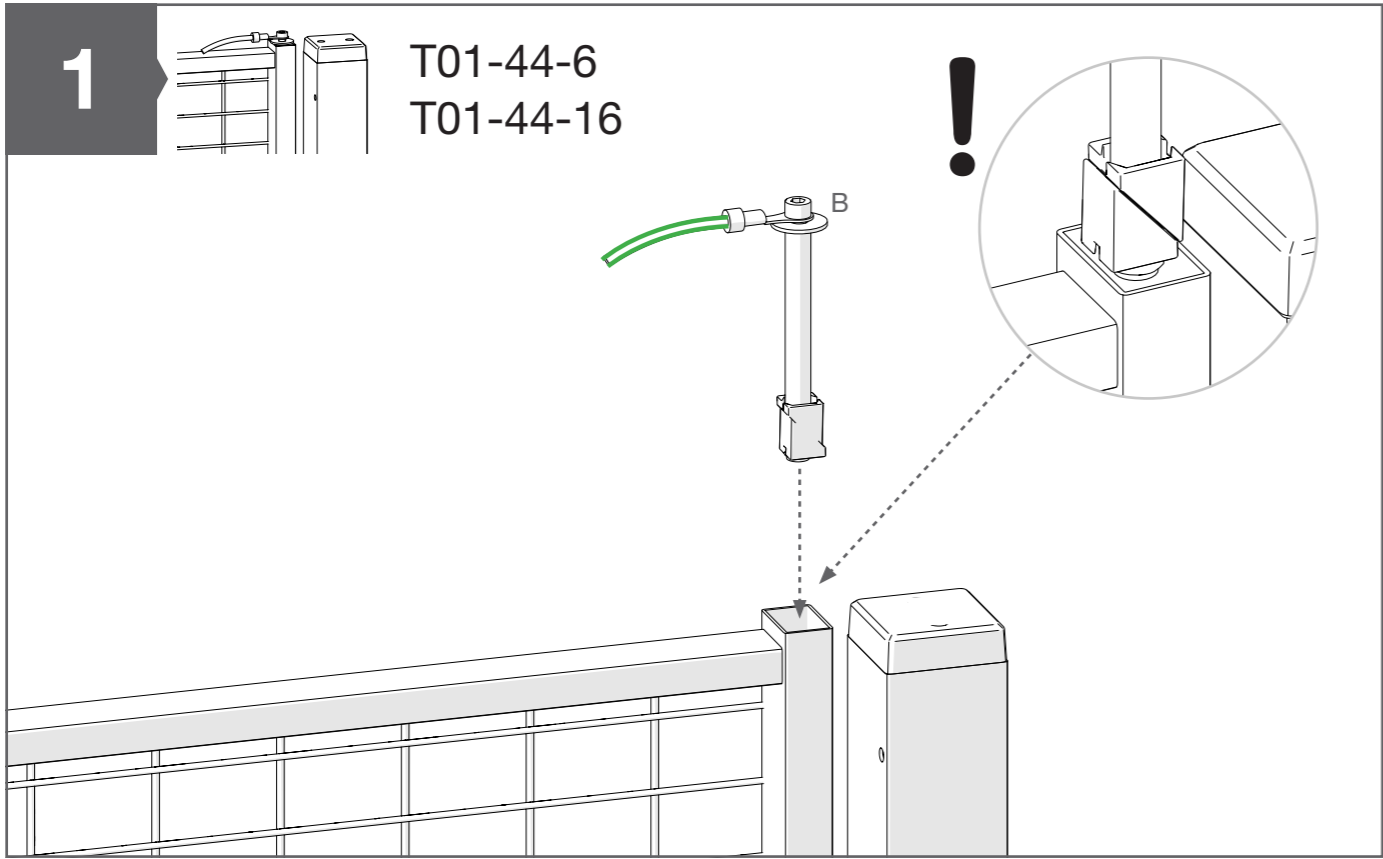

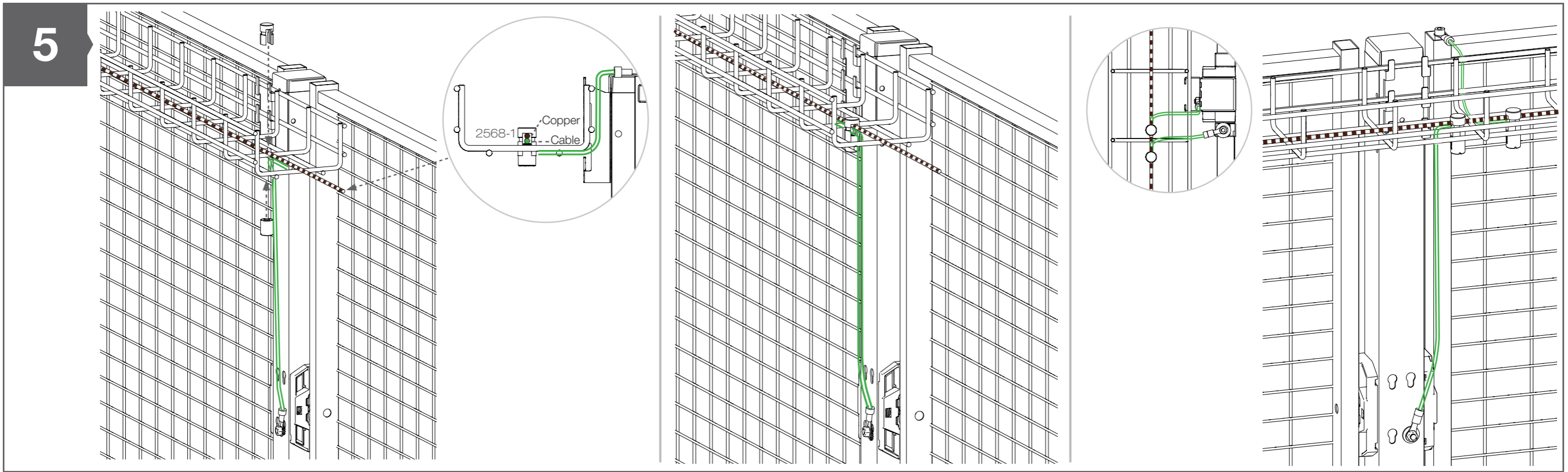
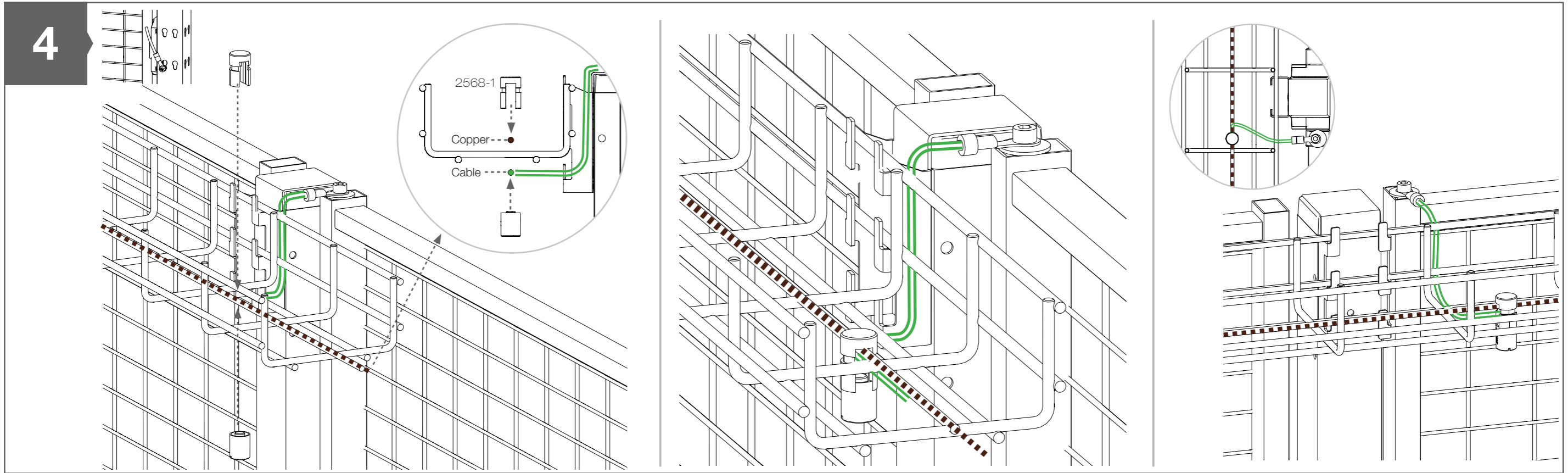

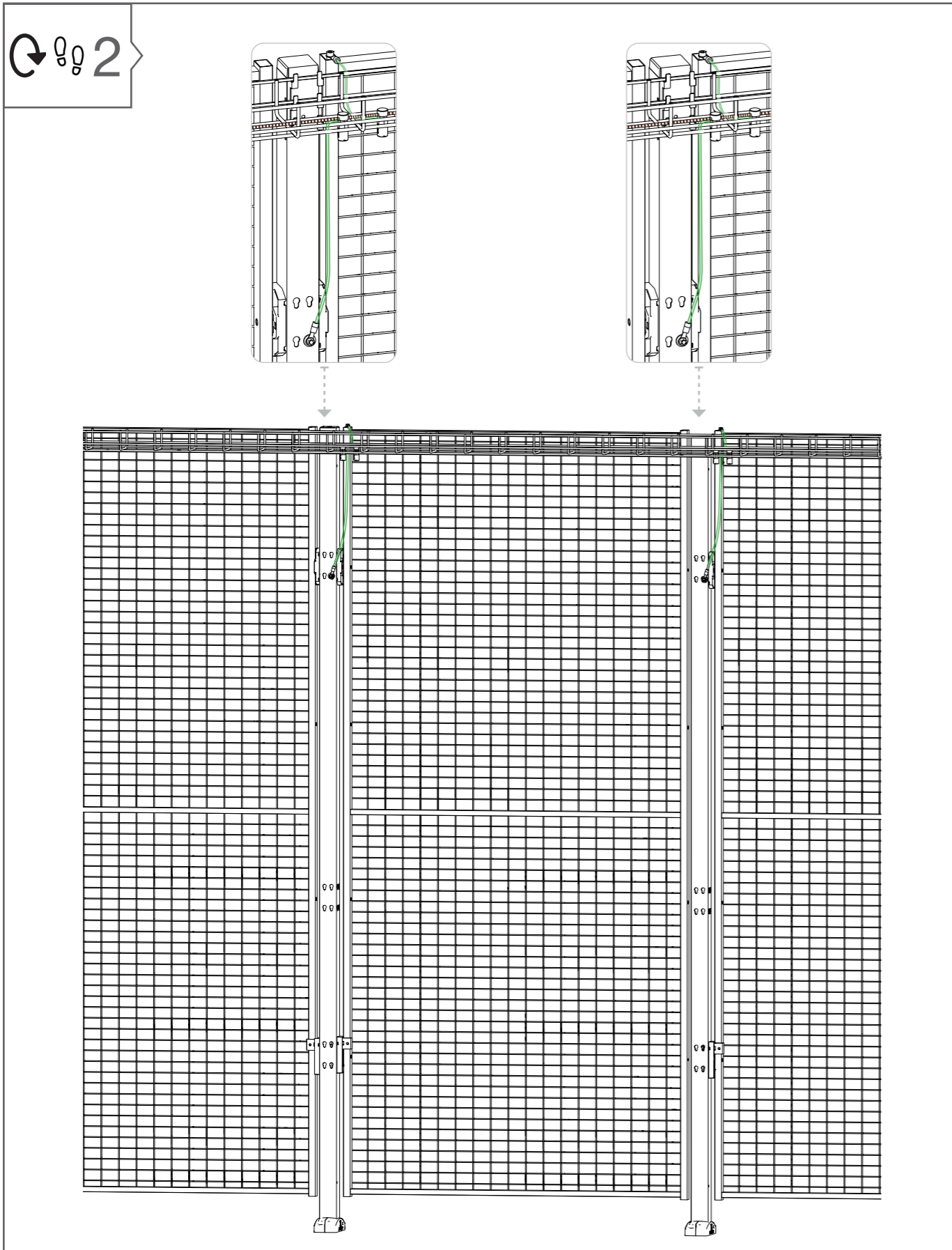

WARNING

Faulty protective bonding or earth bonding may cause severe injury or death by electric shock!



The protective bonding conductor must be connected to the machine/system's protective earthing terminal exclusively by a qualified electrician.

To check and ensure continuity and low impedance, a final inspection must be performed on site by a qualified electrician (compare EN (IEC) 60204-1 chapter 18).

